

最大行程 Maximum Stroke **600mm**    最高速度 Maximum Speed **720mm/s**    马达容量 Motor Output **100W**    最大可搬重量 Max Payload **25kg**

### 基本式样 Specification

位置重复精度 Repeatability	mm	± 0.01		
螺杆导程 Lead	mm	2	6	12
最高转速 Maximum Rotating speed	rpm	3000	3600	3600
最高速度 Maximum linear speed <sup>※1</sup> <sup>※2</sup>	mm/s	100	360	720
最大可搬重量 Maximum Payload	水平使用 Horizontal	kg	25	12
	垂直使用 Vertical	kg	8	2
定格推力 Rated Thrust	N	854	285	142
标准行程 Stroke (increments)	mm	50-600 mm / 50 间隔 (50 increments)		
最大加速度 Maximum acceleration	G	0.3	0.3	0.6
滚珠螺杆 Ball screw	基本动额定负荷 Basic dynamic load rating Ca	N	-	-
	基本静额定负荷 Basic static load rating Coa	N	-	-
直线滑轨 Linear Guide	动态水平负载 Dynamic horizontal (100km)	N	-	-
	静态水平负载 Static Horizontal	N	-	-
固定侧轴承 Fixed bearing	基本静额定负荷 Basic dynamic load rating Cr	N	-	-
	静态容许负荷 Static load rating Cor	N	-	-
AC伺服马达容量 AC Servo Motor Output	W	100		
滚珠螺杆外径 Ball Screw Ø	mm	Ø 10		
联轴器 Coupling	mm	7X8		
原点感应器 Home Sensor	外挂 Outside	FF-U674(NPN)		

※1 马达加减速设定0.2秒, Acceleration and deceleration value is set 0.2 second.  
※2 长行程时, 会产生螺杆偏摆, 需将速度降低 (线速度请参阅尺寸图下方表格)  
During a long stroke, it causes ballscrew deflection, the speed must reduce. (Please refer to the linear velocity from the data sheet below the dimension graph.)

### 容许负载力距表 Allowable Overhang

水平安装 Horizontal Installation				壁挂安装 Wall Installation				垂直安装 Vertical Installation			
导程 2 Lead	A	B	C	导程 2 Lead	A	B	C	导程 2 Lead	A	C	
12kg	1000	55	80	12kg	80	55	1000	4kg	192	192	
18kg	750	35	50	18kg	50	35	750	8kg	96	96	
25kg	500	23	32	25kg	32	23	500	-	-	-	
10kg	459	52	70	10kg	71	52	450	3kg	200	200	
15kg	292	32	44	15kg	44	32	292	5kg	120	120	
20kg	208	22	30	20kg	30	22	208	-	-	-	
8kg	250	58	71	8kg	75	58	250	1.5kg	338	338	
10kg	196	44	55	10kg	54	44	196	2kg	253	253	
12kg	160	36	44	12kg	44	36	160	-	-	-	

### 静额定扭矩 Static Loading Moment

MY	MP	MR
79	79	116

\*力矩表所表示的数据, 代表荷重的重心位置单一方向容许悬出的长度。  
The data represented by the moment table is the center of gravity of the load. The length of the overhang is allowed in a single direction.  
\*符合型录范围的正常使用下, 保证寿命为10000公里。  
Operation life is 10,000km when the product is using under the specified conditions.  
\*倒吊使用无法套用标准规范, 如有需求请咨询我司业务。  
Data information is not for ceiling-mount inverse use.  
Contact us for the details if you want to apply ceiling-mount inverse usage.

### 搭配伺服马达一览表 Suitable Motor Brand

厂牌 Brand	马达记号 Mark	刹车有无 Brake	马达容易 Watt	电源电压 AC-voltage	伺服马达型号 Motor Model	驱动器型号 Driver Model
三菱 Mitsubishi	M	无刹车 (水平式样) No Brake (Horizontal Type)	100	220	HG-KR13	MR-J4-10A
		有刹车 (垂直式样) With Brake (Vertical Type)	100	220	HG-KR13B	MR-J4-10A
松下 Panasonic	P	无刹车 (水平式样) No Brake (Horizontal Type)	100	220	MSMD012G1U	MADHT1505
		有刹车 (垂直式样) With Brake (Vertical Type)	100	220	MSMD012G1V	MADHT1505
台达 Delta	T	无刹车 (水平式样) No Brake (Horizontal Type)	100	220	ECMA-C20401ES	ASD-B20121-B
		有刹车 (垂直式样) With Brake (Vertical Type)	100	220	ECMA-C20401FS	ASD-B20121-B

### 型号表示方式 Ordering Method

## GCH4 - L2-100 - BC- M10B-C 4 - 0001



## BC 马达外露 Motor Exposed

单位 Unit: mm

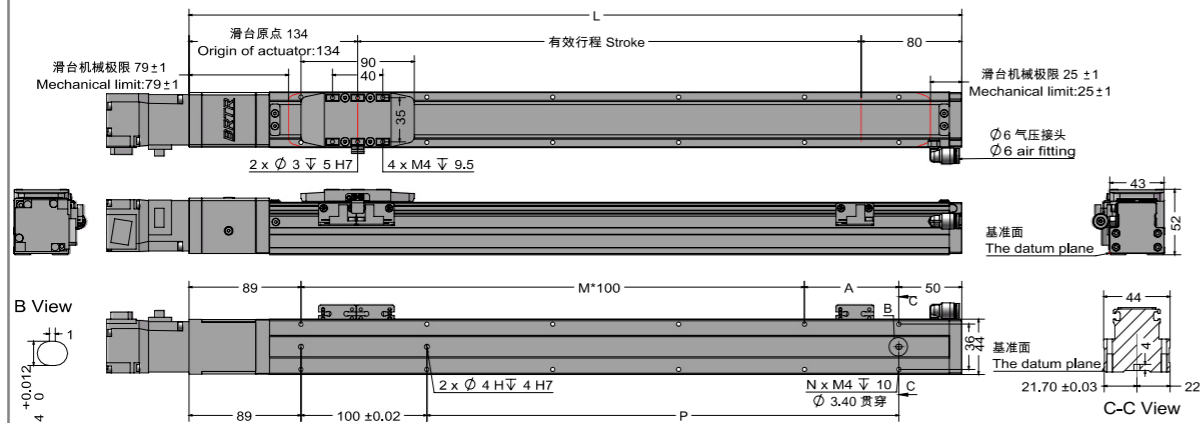

有效行程 Stroke	50 <sup>±2</sup>	100	150	200	250	300	350	400	450	500	550	600		
极限行程 Limit Stroke (±1)	70	120	170	220	270	320	370	420	470	520	570	620		
L	264	314	364	414	464	514	564	614	664	714	764	814		
A	25	75	25	75	25	75	25	75	25	75	25	75		
M	1	1	2	2	3	3	4	4	5	5	6	6		
N	6	6	8	8	10	10	12	12	14	14	16	16		
P	25	75	125	175	225	275	325	375	425	475	525	575		
KG	0.95	1.12	1.29	1.47	1.65	1.83	2.01	2.19	2.37	2.55	2.73	2.91		
线速度 Linear Speed (mm/s)														
导程 Lead 2	300													
导程 Lead 6	600													
导程 Lead 12	720													
												330	320	270
												660	640	540

※ 2行程50时, 因本体上锁式固定孔会被滑座遮住, 仅能使用4支螺丝固定, 建议客户本体用下锁式固定孔锁附。When the stroke is 50mm, if fixing the body from the top to the bottom, the fixing hole will be blocked by slider and only can be uses 4 screws to fix, as a result, suggest that fixing actuator body from the bottom to the top.

## BL 马达左折 Motor Left Side

单位 Unit: mm

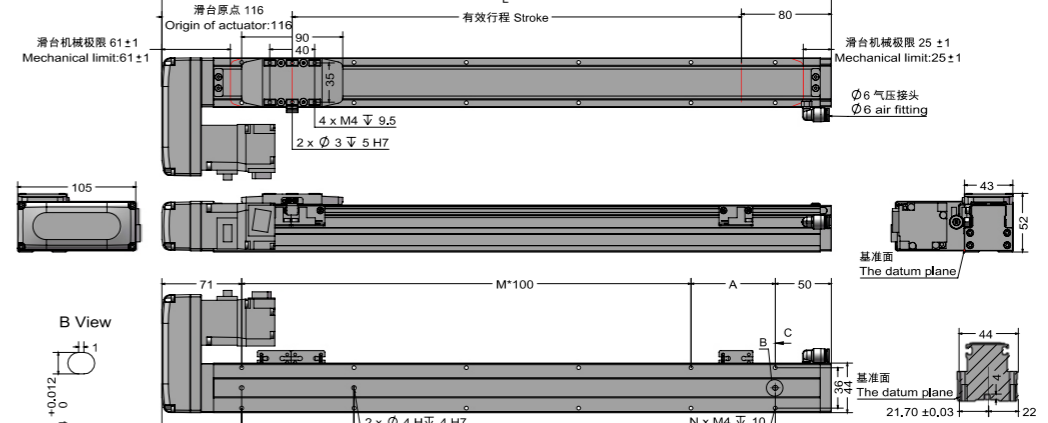

有效行程 Stroke	50 <sup>±2</sup>	100	150	200	250	300	350	400	450	500	550	600		
极限行程 Limit Stroke (±1)	70	120	170	220	270	320	370	420	470	520	570	620		
L	246	296	346	396	446	496	546	596	646	696	746	796		
A	25	75	25	75	25	75	25	75	25	75	25	75		
M	1	1	2	2	3	3	4	4	5	5	6	6		
N	6	6	8	8	10	10	12	12	14	14	16	16		
P	25	75	125	175	225	275	325	375	425	475	525	575		
KG	0.95	1.12	1.29	1.47	1.65	1.83	2.01	2.19	2.37	2.55	2.73	2.91		
线速度 Linear Speed (mm/s)														
导程 Lead 2	300													
导程 Lead 6	600													
导程 Lead 12	720													
												330	320	270
												660	640	540

※ 2行程50时, 因本体上锁式固定孔会被滑座遮住, 仅能使用4支螺丝固定, 建议客户本体用下锁式固定孔锁附。When the stroke is 50mm, if fixing the body from the top to the bottom, the fixing hole will be blocked by slider and only can be uses 4 screws to fix, as a result, suggest that fixing actuator body from the bottom to the top.

## BM 马达下折 Motor Bottom Side

单位 Unit: mm

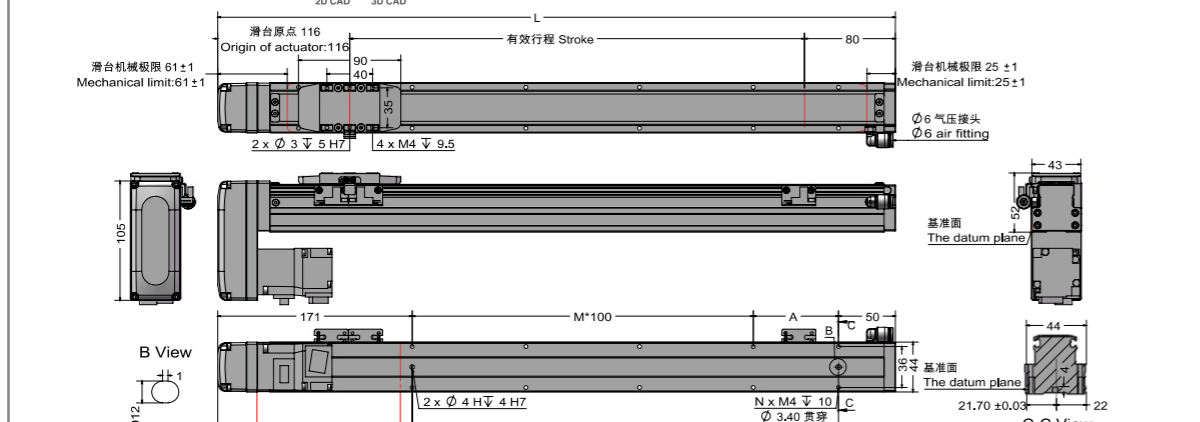

有效行程 Stroke	50 <sup>±2</sup>	100	150	200	250	300	350	400	450	500	550	600		
极限行程 Limit Stroke (±1)	70	120	170	220	270	320	370	420	470	520	570	620		
L	246	296	346	396	446	496	546	596	646	696	746	796		
A	25	75	25	75	25	75	25	75	25	75	25	75		
M	1	1	2	2	3	3	4	4	5	5	6	6		
N	6	6	8	8	10	10	12	12	14	14	16	16		
P	25	75	125	175	225	275	325	375	425	475	525	575		
KG	0.95	1.12	1.29	1.47	1.65	1.83	2.01	2.19	2.37	2.55	2.73	2.91		
线速度 Linear Speed (mm/s)														
导程 Lead 2	300													
导程 Lead 6	600													
导程 Lead 12	720													
												330	320	270
												660	640	540

※ 1 马达下折时, 若选用刹车马达, 或是超出马达总长度限制时, 无法套用标准PIN孔, 如有需求, 请联系我司业务。When motor with brake assembled on lower side, or the total length over than spec limit, it may not use standard pinhole. Please contact our sales department if you need more information & requirement.  
※ 2行程50时, 因本体上锁式固定孔会被滑座遮住, 仅能使用4支螺丝固定, 建议客户本体用下锁式固定孔锁附。When the stroke is 50mm, if fixing the body from the top to the bottom, the fixing hole will be blocked by slider and only can be uses 4 screws to fix, as a result, suggest that fixing actuator body from the bottom to the top.

## BR 马达右折 Motor Right Side

单位 Unit: mm

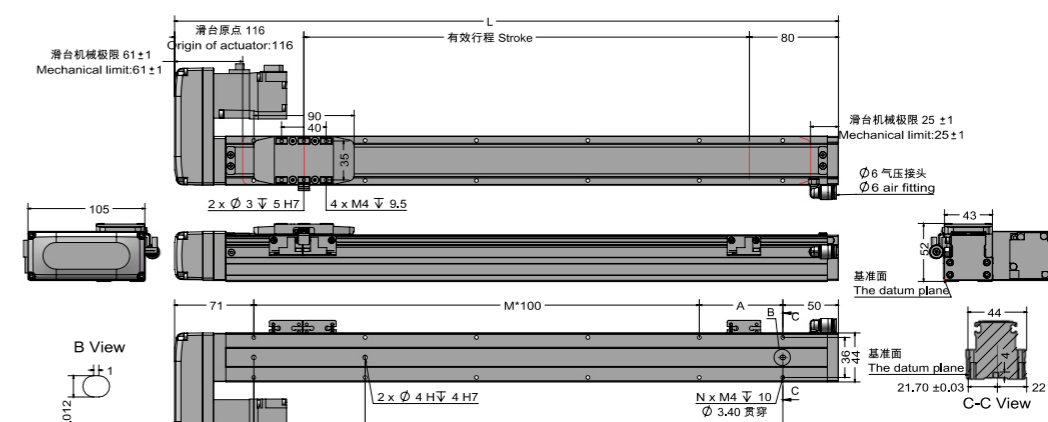

有效行程 Stroke	50 <sup>±2</sup>	100	150	200	250	300	350	400	450	500	550	600		
极限行程 Limit Stroke (±1)	70	120	170	220	270	320	370	420	470	520	570	620		
L	246	296	346	396	446	496	546	596	646	696	746	796		
A	25	75	25	75	25	75	25	75	25	75	25	75		
M	1	1	2	2	3	3	4	4	5	5	6	6		
N	6	6	8	8	10	10	12	12	14	14	16	16		
P	25	75	125	175	225	275	325	375	425	475	525	575		
KG	0.95	1.12	1.29	1.47	1.65	1.83	2.01	2.19	2.37	2.55	2.73	2.91		
线速度 Linear Speed (mm/s)														
导程 Lead 2	300													
导程 Lead 6	600													
导程 Lead 12	720													
												330	320	270
												660	640	540

※ 2行程50时, 因本体上锁式固定孔会被滑座遮住, 仅能使用4支螺丝固定, 建议客户本体用下锁式固定孔锁附。When the stroke is 50mm, if fixing the body from the top to the bottom, the fixing hole will be blocked by slider and only can be uses 4 screws to fix, as a result, suggest that fixing actuator body from the bottom to the top.